



ATTENTION
OBSERVE PRECAUTIONS
FOR HANDLING
ELECTROSTATIC
DISCHARGE
SENSITIVE
DEVICES

1、Features/特征:

- Emitting Color/发光颜色: White/白色
- Lens Type/封装特性: Yellow Diffused/黄色散射
- Device Outline/外形特征: 3.5×2.8×0.8 (unit:mm)
- HBM ESD:Class 2/人体抗静电指标: Class 2
- Pb-Free/无铅
- RoHS compliant/符合 RoHS 标准

2、Applications/应用:

- Backlight for Mobile, Machine Vision, LCD Display/手机、电话、显示屏背光源
- Indoor Lighting /室内照明

3、Outline Dimensions/产品外形尺寸:

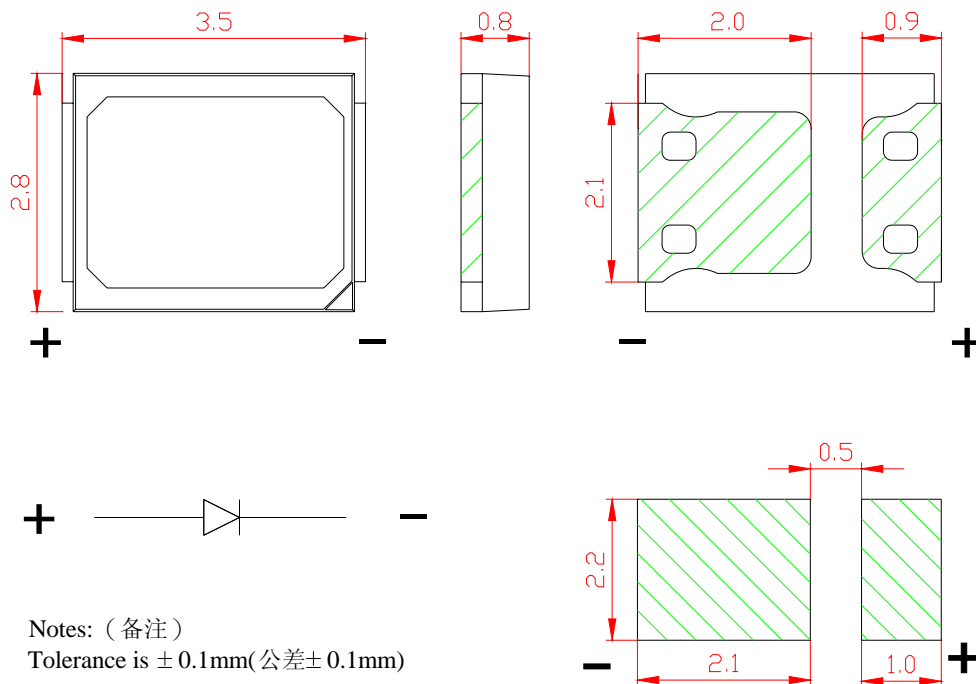

参考焊盘尺寸



4、Absolute maximum ratings/极限参数 (Ta = 25℃):

Parameter 参数	Symbol 符号	Value 参数	Unit 单位
Power Dissipation 损耗功率	Pd	1000	mW
Reverse Voltage 反向电压	VR	5	V
Pulse Current 正向峰值电流 ^[1]	IFp	500	mA
Forward Current 正向工作电流	IFm	300	mA
Operating Temperature 工作温度范围	Topr	- 40 ~ +85	℃
Storage Temperature 储存温度范围	Tstr	- 40 ~ +100	℃

Notes/备注: [1]. 0.1ms pulse width, 1/10 Duty. / [1] 脉冲宽度0.1ms, 占空比1/10。

5、Electrical and optical characteristics/光电参数 (Ta = 25℃):

Parameter 参数	Symbol 符号	Test Condition 测试条件	Value 参数			Unit 单位
			Min.	Typ.	Max.	
Forward Voltage 正向电压	VF	IF = 300mA	—	3.2	3.6	V
Reverse Current 反向电流	IR	VR = 5V	—	—	30	μ A
Color Correlated Temperature 色温	CCT	IF = 300mA	4730	—	13000	K
Luminous Flux 光通量	Φ	IF = 300mA	—	100	—	Lm
color rendering index 显色指数	Ra	IF = 300mA	80	—	—	—
Viewing Angle 发光指向角	2 θ 1/2	IF = 300mA	—	120	—	Deg.

Notes/备注: Tolerance 误差: VF: ±0.10V, Φ: ±15%, 其它: ±5%



6、Product Ranks/产品分档范围:

亮度分档标准		电压分档标准	
光通量 Φ (Lm) IF=300mA	代表符号	正向电压 V_F 值(V) IF=300mA	代表符号
90-100	L90	2.80--2.90	N
100-110	L100	2.90--3.00	P
110-120	L110	3.00—3.10	Q
		3.10—3.20	R
		3.20—3.30	S
		3.30—3.40	T
		3.40—3.50	U
		3.50—3.60	V

Notes/备注: Rank error/分档误差: V_F : $\pm 0.10V$, Φ : $\pm 15\%$



色坐标分档:

色坐标误差: ± 0.01

代码	轴	参数				代码	轴	参数			
Wa1	X	0.2568	0.2623	0.2666	0.2614	Wa2	X	0.2614	0.2666	0.2710	0.2661
	Y	0.2848	0.2920	0.2854	0.2786		Y	0.2786	0.2854	0.2788	0.2725
Wa3	X	0.2661	0.2710	0.2753	0.2708	Wa4	X	0.2708	0.2753	0.2796	0.2754
	Y	0.2725	0.2788	0.2723	0.2664		Y	0.2664	0.2723	0.2657	0.2602
Wa5	X	0.2754	0.2796	0.2842	0.2804	Wa6	X	0.2623	0.2679	0.2719	0.2666
	Y	0.2602	0.2657	0.2587	0.2538		Y	0.2920	0.2992	0.2922	0.2854
Wa7	X	0.2666	0.2719	0.2758	0.2710	Wa8	X	0.2710	0.2758	0.2798	0.2753
	Y	0.2854	0.2922	0.2852	0.2788		Y	0.2788	0.2852	0.2781	0.2723
Wa9	X	0.2753	0.2798	0.2838	0.2796	Wa10	X	0.2796	0.2838	0.2880	0.2842
	Y	0.2723	0.2781	0.2711	0.2657		Y	0.2657	0.2711	0.2637	0.2587
Wa11	X	0.2679	0.2735	0.2771	0.2719	Wa12	X	0.2719	0.2771	0.2807	0.2758
	Y	0.2992	0.3065	0.2990	0.2922		Y	0.2922	0.2990	0.2915	0.2852
Wa13	X	0.2758	0.2807	0.2844	0.2798	Wa14	X	0.2798	0.2844	0.2880	0.2838
	Y	0.2852	0.2915	0.2840	0.2781		Y	0.2781	0.2840	0.2766	0.2711
Wa15	X	0.2838	0.2880	0.2918	0.2880	Wa16	X	0.2735	0.2791	0.2823	0.2771
	Y	0.2711	0.2766	0.2687	0.2637		Y	0.3065	0.3138	0.3058	0.2990
Wa17	X	0.2771	0.2823	0.2856	0.2807	Wa18	X	0.2807	0.2856	0.2889	0.2844
	Y	0.2990	0.3058	0.2979	0.2915		Y	0.2915	0.2979	0.2899	0.2840
Wa19	X	0.2844	0.2889	0.2922	0.2880	Wa20	X	0.2880	0.2922	0.2957	0.2918
	Y	0.2840	0.2899	0.2820	0.2766		Y	0.2766	0.2820	0.2737	0.2687
Wb1	X	0.2791	0.2823	0.2892	0.2863	Wb2	X	0.2823	0.2856	0.2920	0.2892
	Y	0.3138	0.3058	0.3140	0.3224		Y	0.3058	0.2979	0.3055	0.3140
Wb3	X	0.2856	0.2889	0.2949	0.2920	Wb4	X	0.2889	0.2922	0.2977	0.2949
	Y	0.2979	0.2899	0.2971	0.3055		Y	0.2899	0.2820	0.2886	0.2971
Wb5	X	0.2863	0.2892	0.2960	0.2935	Wb6	X	0.2892	0.2920	0.2984	0.2960
	Y	0.3224	0.3140	0.3221	0.3311		Y	0.3140	0.3055	0.3131	0.3221
Wb7	X	0.2920	0.2949	0.3008	0.2984	Wb8	X	0.2949	0.2977	0.3032	0.3008
	Y	0.3055	0.2971	0.3042	0.3131		Y	0.2971	0.2886	0.2952	0.3042
Wb9	X	0.2935	0.2960	0.3028	0.3008	Wb10	X	0.2960	0.2984	0.3048	0.3028
	Y	0.3311	0.3221	0.3303	0.3398		Y	0.3221	0.3131	0.3208	0.3303
Wb11	X	0.2984	0.3008	0.3068	0.3048	Wb12	X	0.3008	0.3032	0.3088	0.3068
	Y	0.3131	0.3042	0.3113	0.3208		Y	0.3042	0.2952	0.3018	0.3113



代码	轴	参数				代码	轴	参数			
Wc1	X	0.3014	0.3028	0.3116	0.3107	Wc2	X	0.3028	0.3041	0.3126	0.3116
	Y	0.3368	0.3303	0.3392	0.3461		Y	0.3303	0.3240	0.3323	0.3392
Wc3	X	0.3041	0.3054	0.3134	0.3126	Wc4	X	0.3054	0.3068	0.3144	0.3134
	Y	0.3240	0.3177	0.3255	0.3323		Y	0.3177	0.3113	0.3186	0.3255
Wc5	X	0.3068	0.3081	0.3153	0.3144	Wc6	X	0.3107	0.3116	0.3204	0.3200
	Y	0.3113	0.3048	0.3118	0.3186		Y	0.3461	0.3392	0.3480	0.3553
Wc7	X	0.3116	0.3126	0.3210	0.3204	Wc8	X	0.3126	0.3134	0.3215	0.3210
	Y	0.3392	0.3323	0.3407	0.3480		Y	0.3323	0.3255	0.3334	0.3407
Wc9	X	0.3134	0.3144	0.3220	0.3215	Wc10	X	0.3144	0.3153	0.3225	0.3220
	Y	0.3255	0.3186	0.3260	0.3334		Y	0.3186	0.3118	0.3188	0.3260
Wd1	X	0.3201	0.3207	0.3292	0.3291	Wd2	X	0.3207	0.3213	0.3293	0.3292
	Y	0.3534	0.3459	0.3527	0.3613		Y	0.3459	0.3362	0.3425	0.3527
Wd3	X	0.3213	0.3220	0.3295	0.3293	Wd4	X	0.3220	0.3227	0.3295	0.3295
	Y	0.3362	0.3267	0.3323	0.3425		Y	0.3267	0.3170	0.3226	0.3323
Wd5	X	0.3291	0.3292	0.3378	0.3382	Wd6	X	0.3292	0.3293	0.3373	0.3378
	Y	0.3613	0.3527	0.3596	0.3693		Y	0.3527	0.3425	0.3488	0.3596
Wd7	X	0.3293	0.3295	0.3368	0.3373	Wd8	X	0.3295	0.3295	0.3364	0.3368
	Y	0.3425	0.3323	0.3380	0.3488		Y	0.3323	0.3226	0.3284	0.3380
We1	X	0.3382	0.3378	0.3462	0.3473	We2	X	0.3378	0.3373	0.3452	0.3462
	Y	0.3693	0.3596	0.3664	0.3772		Y	0.3596	0.3488	0.3550	0.3664
We3	X	0.3373	0.3368	0.3442	0.3452	We4	X	0.3368	0.3364	0.3434	0.3442
	Y	0.3488	0.3380	0.3438	0.3550		Y	0.3380	0.3284	0.3339	0.3438
We5	X	0.3473	0.3462	0.3547	0.3562	We6	X	0.3462	0.3452	0.3531	0.3547
	Y	0.3772	0.3664	0.3732	0.3851		Y	0.3664	0.3550	0.3613	0.3732
We7	X	0.3452	0.3442	0.3515	0.3531	We8	X	0.3442	0.3434	0.3502	0.3515
	Y	0.3550	0.3438	0.3493	0.3613		Y	0.3438	0.3339	0.3395	0.3493



Diagram

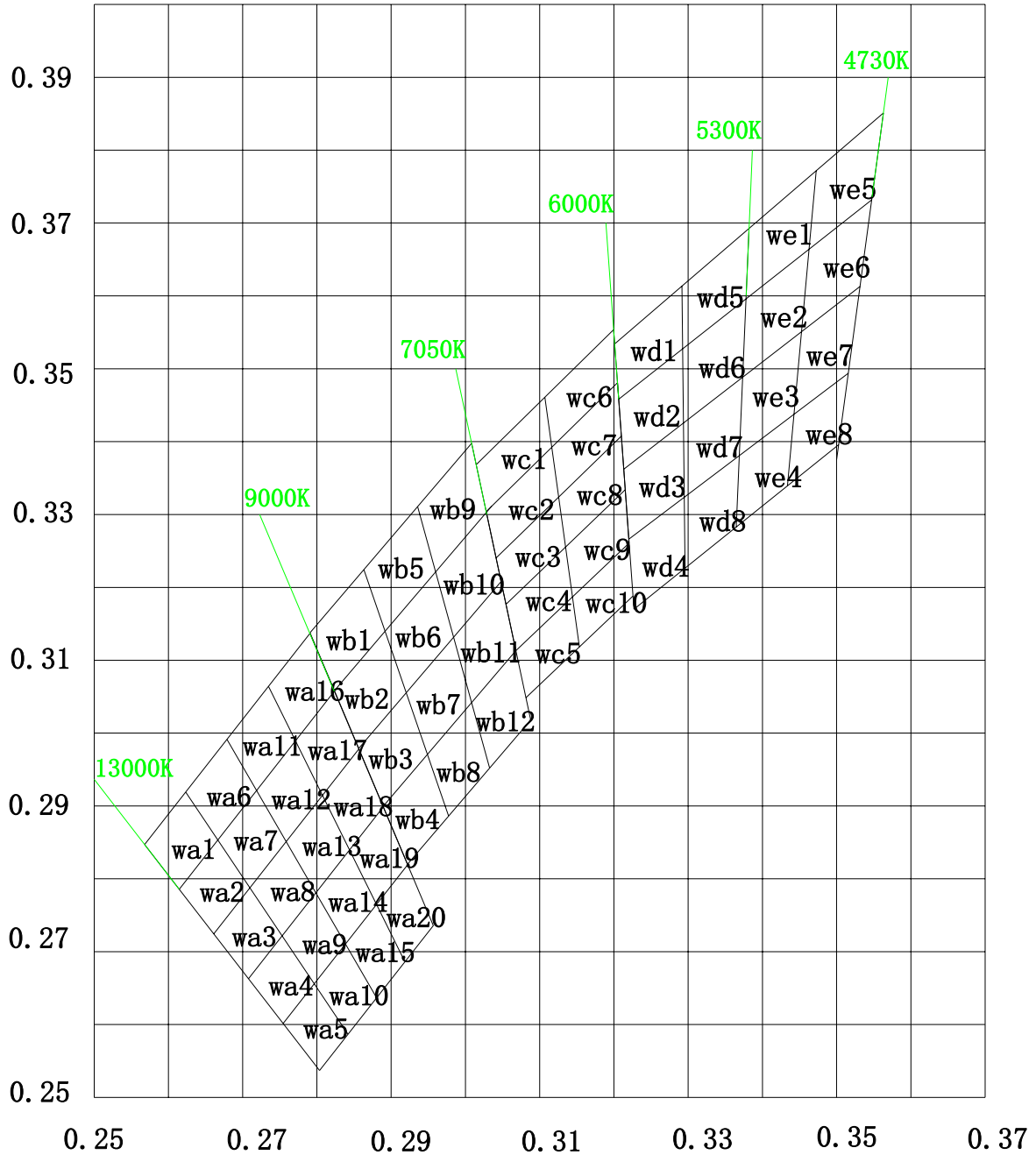



7、Typical electrical/optical characteristic curves/光电特性曲线:

Fig.1 正向电流 Vs. 正向电压

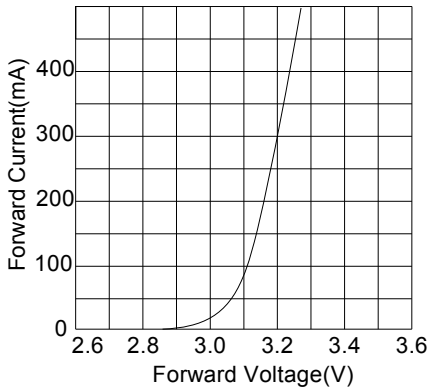

Fig.2 相对亮度 Vs. 正向电流

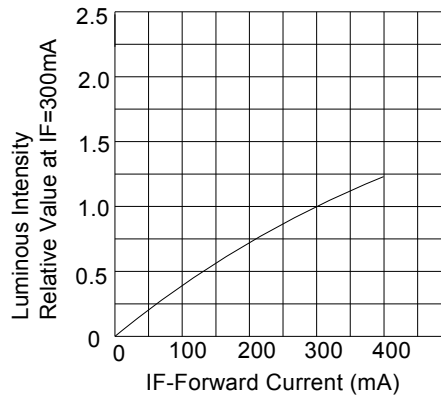

Fig.3 正向电流 Vs. 环境温度

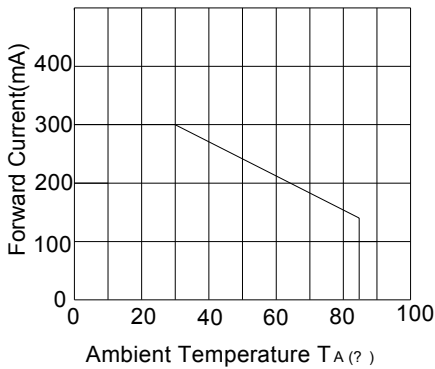

Fig.4 相对亮度 Vs. 环境温度

